



Main features

- Range of measurement: from 100 N to 2kN
- Accuracy class: 0,5%
- Corrosion resistant
- Internally generated calibration signal
- Orientation of the axis of maximum sensitivity for 35° independently from the position of the fixing holes
- Grade of protection: IP65 (DIN 40050)
- Integrated protection against overloads

TR series force transducers are used to measure the tension that plastic films or tapes exert on the guide rollers of the machinery used to coil them.

Mounted at the ends of a fixed or transmission shaft on the machine chassis, they perform the function of force sensors and bearing for the ends of the shaft.

They are used on both fixed and rotating shafts.

TR transducers are supplied with the adaptor flange for fixing, with 4 M6 screws or with one central M10 or M12 screw.

TECHNICAL DATA

Accuracy	0,50%	
Nominal full scale load (Ln)	100N...2kN	
Nominal output at FSO	2mV/V	
Output tolerance at Ln	<± 1% FSO	
Combined errors: Non linearity Hysteresis, Repeatability	< ± 0,5% FSO	
Creep (after 30 min. at Ln)	< ± 0,06% FSO	
Zero load out of balance signal	< ± 1% FSO	
Thermal drift in compensated range	Sensitivity	< ± 0,005% FSO°C
	Zero	< ± 0,01% FSO°C
	Calibration	-
Nominal bridge resistance	350 Ohm	
Isolation resistance	> 10 GOhm	
Nominal supply voltage	10V	
Maximum supply voltage	15 V	
Compensated temperature range	-10...+50°C	
Maximum temperature range	-20...+60°C	
Storage temperature range	-30...+80°C	
Permitted static load	100% Ln	
Maximum applicable load	300% Ln	
Rupture load	> 500% Ln [6 kN max.]	
Maximum static lateral load	150% Ln	
Maximum elastic deformation at Ln	< 0,5 mm	
Grade of protection (DIN40050)	IP65	
Electr. connections: Connector	VPT02A10-6PT2	
Elastic element material	Aluminium (100...1kN) Stainless steel (1.5kN - 2 kN)	
Case material	Anodised aluminium (Flange and bearing in AISI 303)	

MECHANICAL DIMENSIONS

Model for rollers with revolving hub.

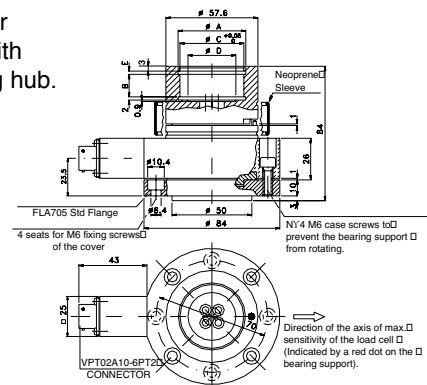

Model for rollers with fixed hub.

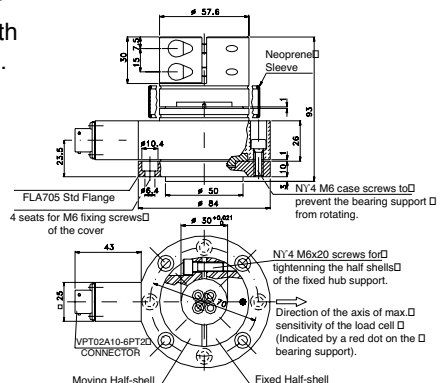

Cuscinetto	øA	B	øC	øD	E
35x15 H11	37	14,5	35	20	1,6
40x17 H12	42,5	14,25	40	30	1,85

Valori delle misure in millimetri (± 0,1)

Coppia di serraggio consigliata per le viti di fissaggio M6 di 7Nm

ELECTRICAL CONNECTIONS

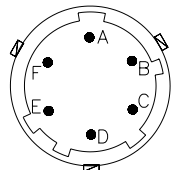

VPT02A10-6PT2
CONNECTOR

If the transducer is supplied complete with prewired connection cable, the colour code is that indicated in the table.

Cells connected in parallel

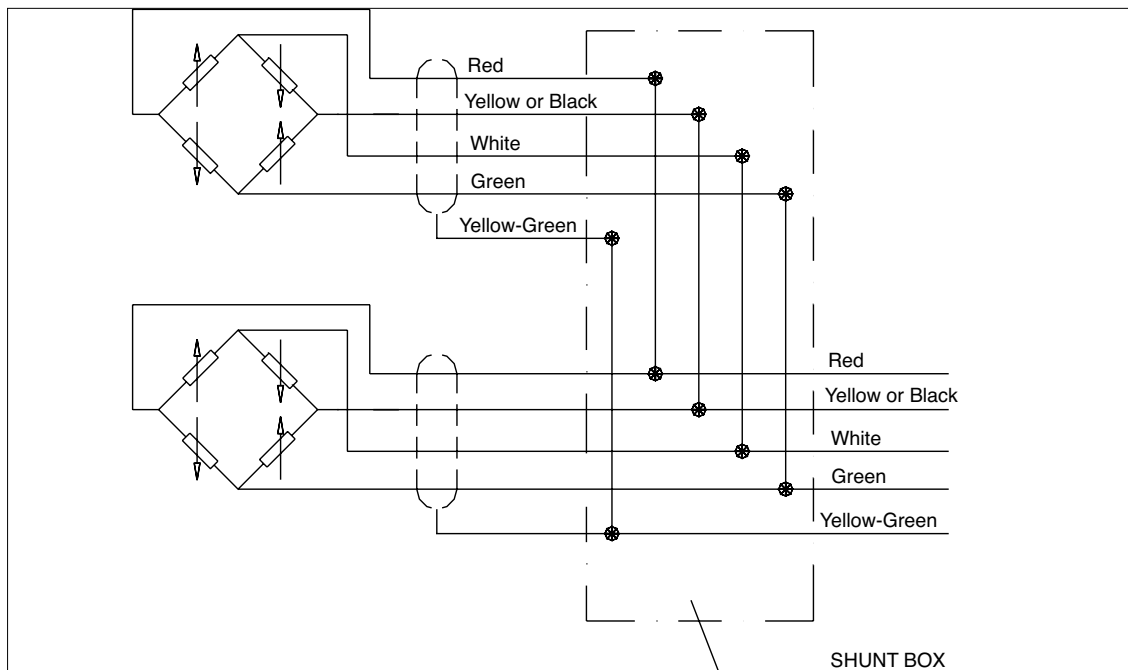

In systems that use several cells, the parallel connection automatically sums the loads on each individual cell.

Using this method of measurement, the maximum load will be the sum of the loads on the individual cells and the sensitivity will be the average value of these cells.

It is important that the user ensures that no cell is stressed beyond its maximum rating under any load condition.

CONVERSION TABLE

Kg	N	Lb
1	9.807	2.205
0.102	1	0.225
0.454	4.448	1

FLANGE

Standard adaptor flange
(see mechanical dimensions drawing)

FLA705

Central fixing
Central fixing

FLA711
FLA715

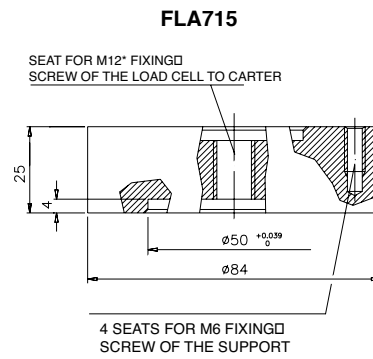
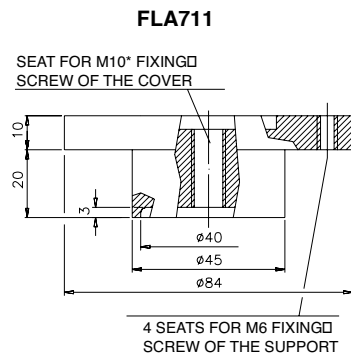

* Recommended torque **75Nm**

CALCULATION OF RESULTANT APPLIED TO CELL

F = Resultant

T = Tension in laminate

P = Roll weight

The red point on the bearing support identifies the axis of maximum cell sensitivity and therefore the direction that **F** has to take with respect to the transducer.

The formulas are valid for the configuration with two load cells where the forces (**T** and **P**) will be divided on both cells

HORIZONTAL RESULTANT	VERTICAL RESULTANT	DOWNWARD RESULTANT	UPWARD RESULTANT
$F = \frac{T}{2} \cdot 2 \cdot \cos \alpha$	$F = \frac{T}{2} \cdot 2 \cdot \cos \alpha + \frac{P}{2}$	$F = \frac{T}{2} \cdot 2 \cdot \cos \alpha + \frac{P}{2} \cdot \cos \beta$	$F = \frac{T}{2} \cdot 2 \cdot \cos \alpha - \frac{P}{2} \cdot \cos \beta$
<p>This configuration gives the best performance because it does not consider roll weight. It is advised for low tension, to prevent roll weight from representing an excessive fraction of the resultant, with consequent reduction of the usable field. This is the only configuration in which, in the absence of tension T, there is a zero signal of approximately 0 mV/V.</p>	<p>In this configuration, roll weight is completely in the direction of maximum sensitivity of the cell that generates a signal in mV/V positive. This signal should be considered as tare: it will be considered during calibration of the instrument connected to the cell.</p>	<p>In this configuration, roll weight is completely in the direction of maximum sensitivity of the cell that generates a signal in mV/V positive. This signal should be considered as tare: it will be considered during calibration of the instrument connected to the cell.</p>	<p>In this configuration, roll weight is completely in the direction of maximum sensitivity of the cell that generates a signal in mV/V negative. This signal should be considered as tare: it will be considered during calibration of the instrument connected to the cell.</p>

OPTIONAL ACCESSORIES

Radial bearing with stop ring (UNI7437-75) and spacer 35 mm
40 mm

PKIT 602

PKIT 600

Female cable connector Grade of protection IP65

CON 300

6-pin connector with 8m (25ft) cable

C08W

6-pin connector with 15m (50ft) cable

C15W

6-pin connector with 25m (75ft) cable

C25W

6-pin connector with 30m (100ft) cable

C30W

Other lengths

consult factory

Cable colour code	
Conn.	wires
A	Red
B	Black
C	White
D	Green
E	Blue
F	Orange

TR application manual

DOC467

ORDER CODE

Force transducer **TR**

MEASUREMENT RANGE (N)	
0 - 100	N1C
0 - 200	N2C
0 - 350	N3.5C
0 - 500	N5C
0 - 750	N7.5C
0 - 1000	N1M
0 - 1500	N15C
0 - 2000	N20C

EXTERNAL DIAMETER	
35 mm bearing	C35
40 mm bearing	C40
30 mm shaft spindle	P30

If request, it is possible to supply models with non-standard mechanical and/or electrical features.

FLANGE	
1	FLA 705 (standard)
2	FLA711
3	FLA715

Ex.: TR-N3.5C-C40-1

TR force transducer, measurement range 350N, external bearing diameter of 40mm with normal mounting and standard flange.

GEFRAN spa reserves the right to make any kind of design or functional modification at any moment without prior notice.